



# Pulsed-IV Parametric Test Solutions

## Introduction

Pulsed-IV parametric testing is becoming an increasingly common requirement for the development of semiconductor process and the evaluation of semiconductor devices. In recent years, the need for very accurate pulsed IV measurement has increased due to the development of more advanced processes utilizing exotic materials, the push for devices with lower power consumption, and many other factors.

To meet these needs Keysight Technologies, Inc. offers a variety of pulsed-IV parametric test solutions that supply the widest range of pulse widths, voltage/current output, and performance available in the industry. Each solution is well-proven and has already been used by many researchers worldwide to meet various advanced measurement needs. These range from the process development of cutting-edge technologies utilizing high-k gate dielectrics and SOI transistors to the evaluation of more conventional semiconductor process such as GaAs and HEMT or new materials such as SiC, GaN or Organic devices which require both high voltage and high current measurement capabilities.

This selection guide provides an overview and side-by-side comparison of all of Keysight's pulsed-IV parametric test solutions to enable you to determine the best solution to meet your unique needs.

Table 1. Multiple options for advanced pulsed measurement needs

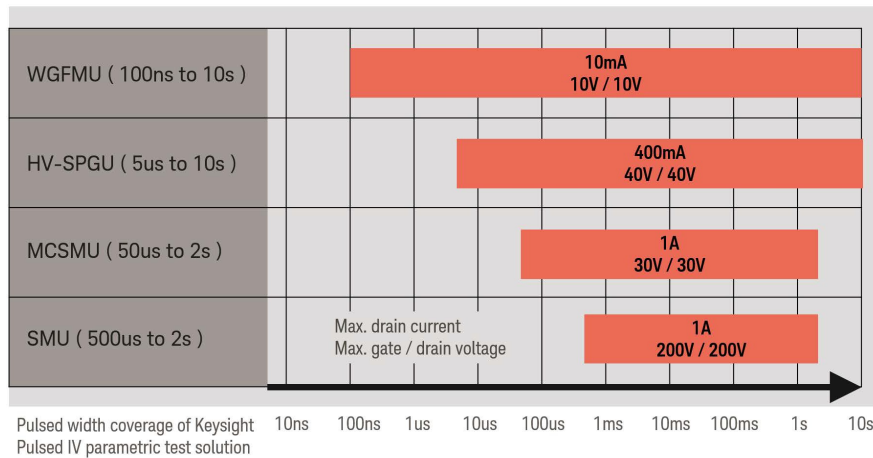

## Selecting the Best Solution to Meet Your Measurement Needs

This selection guide is designed to assist you in comparing Keysight's pulsed-IV measurement solutions and selecting the best one for your measurement applications. By following the steps outlined below you should be able to determine the proper measurement solution to meet your needs.

1. For each of the pulsed-IV specifications listed below, determine your measurement requirements.

Note: Make sure that you understand that some solutions only work for specific device types and configurations.

- Range of pulse widths
  - Required current measurement resolution
  - Maximum voltage and current output capability
  - Dual pulsing capability
2. Determine which solution or solutions meet your pulse width requirements, taking into account your future needs as well.
  3. If more than one solution meets your pulse width requirements, then choose among these solutions using the other measurement parameters (current measurement resolution, current/voltage output capability, etc.). Please keep in mind that there may be some trade-offs among these various parameters (such as accuracy versus voltage/current output capability).
  4. Once you have decided upon a solution re-verify all of the specifications of that solution to make sure that it meets the measurement needs of your applications and devices.
  5. Software is also key factor to control measurement equipment or to synchronize two or more equipment on the Pulsed IV measurement. In some cases, the calculation is required to evaluate current from voltage. Keysight supplies a library of application tests for performing pulsed IV measurement on the EasyEXPERT software.

6. To succeed in making high speed pulsed IV measurement you need more than just the correct measurement instrumentation; you also need to put sufficient forethought into the creation of the test structures that will be used to make the measurement. Attempts to make fast pulsed measurements with conventional DC test structures using DC positioners are in general unlikely to yield good measurement results. In general, fast pulsed measurements require test structures designed for a ground-signal (GS) or ground- signal-ground (GSG) measurement environment and RF positioners. The following figure illustrates this point.

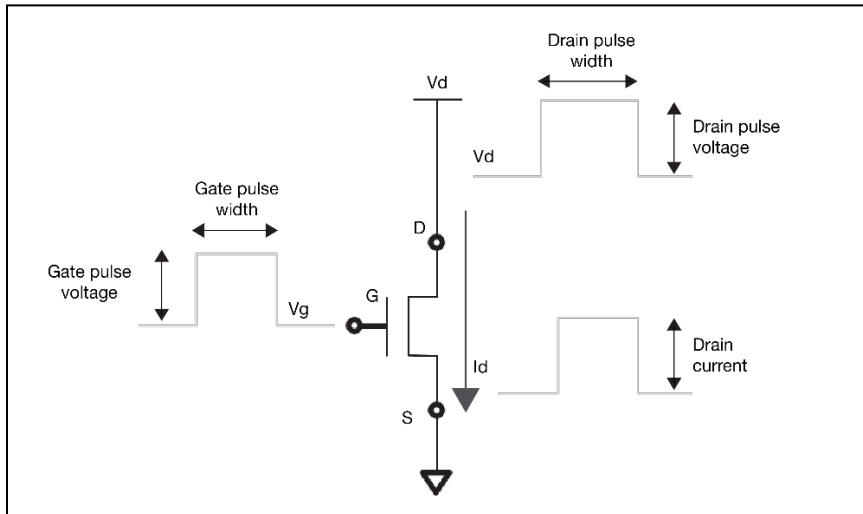

Figure 1. Example of pulsed IV

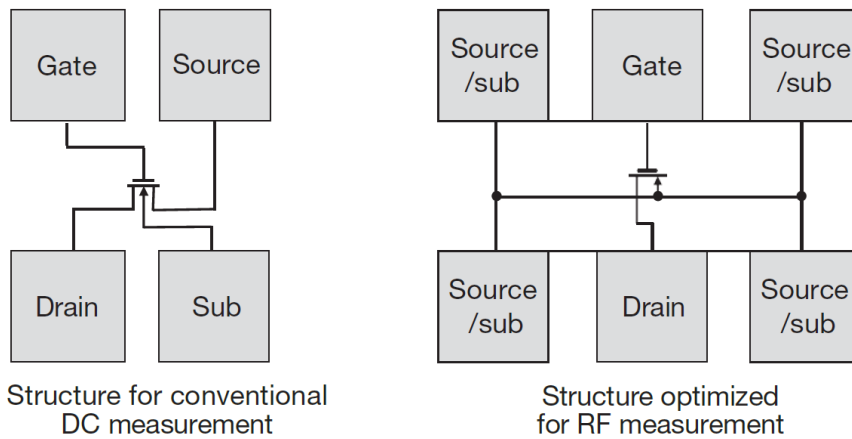

Figure 2. Test structure for DC measurement and RF measurement

## Pulsed-IV Solution Overview—B1530A WGFMU (100 ns to 10 s)

- One hundred nanosecond pulsed IV parametric test solution
- Ultra accurate and fast characterization with 1 nA current measurement resolution
- Waveform generator/fast measurement unit (WGFMU)

The Keysight B1530A WGFMU is a plug-in module for the B1500A semiconductor device analyzer that provides a 100 nanosecond pulsed IV parametric test solution with 1 nA current measurement resolution. The module supports a pulse width range from 100 nsec to 10 sec, and it is the best choice for the precise evaluation of advanced MOSFETs and nano-scale devices such as carbon nanotube (CNT) transistors.

The WGFMU's powerful capabilities, such as a 5 ns sampling interval with 1 nA measurement resolution, cover applications that require both fast and precise measurements.

Each WGFMU module has two channels, so only one module is necessary for three-terminal device evaluation. This solution does not require any other external equipment, complex cabling or custom circuitry. The WGFMU provides a true one-box pulsed IV measurement solution.

### Features

- 1 nA current measurement resolution
- 100 nanosecond gate pulse widths
- Dual pulse capability to apply to both gate and drain
- One-box solution that does not require any other external equipment or complicated cable connections.

### Target device:

- Advanced semiconductor device, such as those fabricated in sub-45 nm processes
- Advanced nanotechnology device, such as CNT FETs, and carbon nanowire devices
- Organic based electronic devices
- Single electron transistor (SET) devices

### For more information:

- Technical overview *Keysight B1530A Waveform Generator/Fast Measurement Unit, 5989-8378EN*



Figure 5. B1530A waveform generator/fast measurement unit on B1500A

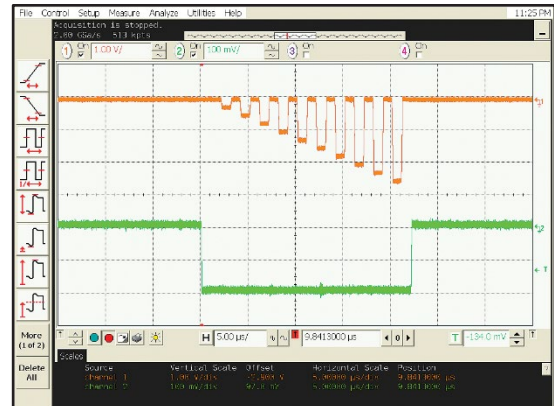

Figure 6. Example of output waveform for Pulsed IV

## Pulsed-IV Solution Overview—B1525A HV-SPGU (5 $\mu$ s to 10 s)

- Medium power pulsed IV parametric test solution
- Fast characterization with 40 V voltage and 400 mA current applying capability
- High-voltage semiconductor pulse generator unit (HV-SPGU)

The Keysight B1525A HV-SPGU is a plug-in module for the B1500A semiconductor device analyzer that provides a 5 microsecond pulsed IV parametric test solution with up to 40 V and 400 mA output capability. It is the best choice for pulsed IV parametric measurement for middle range power devices, such as GaAs and HEMT devices for RF applications.

The HV-SPGU module has an output-voltage monitor capability that supports a 5  $\mu$ s sampling interval, providing superb accuracy. As shown in the block diagram this feature enables the calculation of the output current using the known output impedance of the HV-SPGU module.

The features in HV-SPGU module, the highest accurate voltage forcing among the pulse generators for semiconductor test, arbitrary waveform generation with 10 ns setting resolution, offer best-in-class pulse generation to meet wider application coverage.

Each HV-SPGU module has two channels, so only one module is necessary for three-terminal device evaluation. This solution does not require any other external equipment or complex cabling.

EasyEXPERT supplies a library of application tests for performing pulsed IV measurement using HV-SPGU. The most basic of these application tests permits you to specify single (spot) pulsed measurement on two HV-SPGU channels. The setup screen for this application test is shown in Figure 8.

(Note: Although the B1525A HV-SPGU module's specified minimum pulse width is 50 nsec, the minimum pulse width of this solution is limited by the minimum current measurement interval of B1525A, 5  $\mu$ s.)

## Features

- Up to 40 V and 400 mA output capability
- Pulse width range of 5  $\mu$ s to 10 s
- Dual pulse capability to apply to both Gate and Drain
- One-box solution that does not require any other external equipment or complicated cable connections.
- Easy setup using Keysight EasyEXPERT software
- 40  $\mu$ A current measurement resolution

## Target device:

- Small RF signal MOSFET devices
- GaAs and HEMT devices

## For more information:

- Technical overview *High Power Pulsed IV Solution Utilizing the B1525A HV-SPGU, 5990-3786EN*

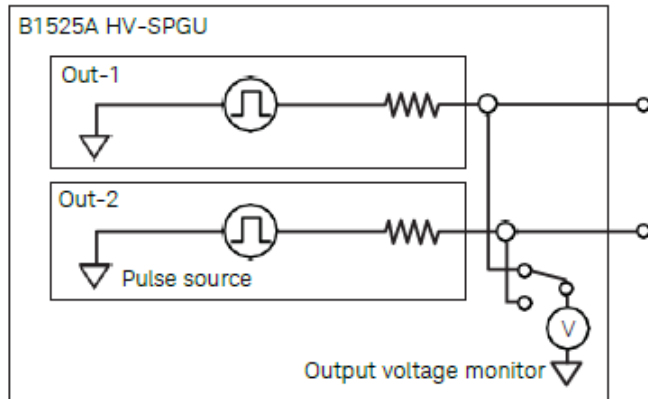

Figure 7. Block diagram of B1525A HV-SPGU

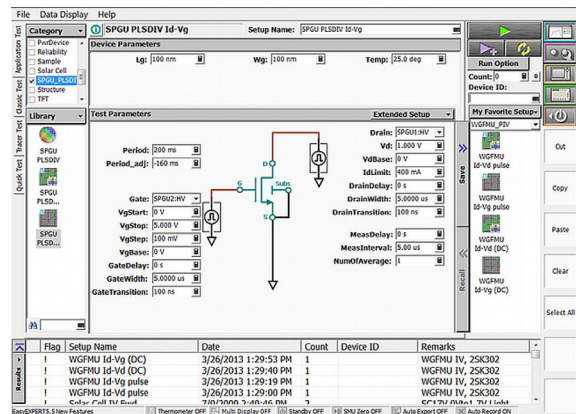

Figure 8. Sample application test for pulsed IV solution using B1525A HV-SPGU

## Pulsed-IV Solution Overview—B1514A MCSMU (50 $\mu$ s to 2 s)

- High power 50  $\mu$ s pulsed IV parametric test solution
- Fast characterization with up to 30 V and 1 A source output
- Medium Current Source/Monitor Unit (MCSMU)

The Keysight B1514A MCSMU is a plug-in module for the B1500A Semiconductor Device Analyzer that provides a 50  $\mu$ s pulsed IV parametric test solution with up to 30 V and 1 A source output. This allows you to avoid self-heating on the IV characteristics measurement for the medium power and high power devices.

The MCSMU is a floating SMU with a short pulse output capability based on the SMU technology which is well known and has been used for a long time by many researchers and engineers both semiconductor and non-semiconductor industries. The N1255A 2 channel connection adapter shown in figure 10 is used to convert the MCSMU dedicated output terminals to traditional SMU output terminals.

The output IV waveforms can be monitored in the Tracer Test mode as shown in figure 11. You can monitor both current and voltage waveforms with 2  $\mu$ s sampling interval. You can set the narrow pulses accurately and easily by optimizing the pulse timing parameters, and obtain accurate result easily.

It is the best choice for the pulsed IV parametric measurement of the medium power and high power devices such as SiC devices, GaN devices, and organic devices.

### Features

- Up to 30 V and 1 A pulse output
- 50  $\mu$ s to 2 s pulse width with minimum 10  $\mu$ s setting resolution
- 4-channel IV waveform monitor with 2  $\mu$ s sampling interval
- Dual synchronous pulsed measurement with source output to gate and drain, with minimum 2  $\mu$ s pulse delay setting
- Proven accurate and conventional pulsed IV measurement
- Easy setup using Keysight EasyEXPERT software

### Target device:

- SiC devices
- GaN devices
- Organic devices

### For more information:

- *Technical overview 30 V — 1 A Pulsed IV Measurement Using the Keysight B1500A's 50  $\mu$ s pulsed MCSMU, 5991-2502EN*



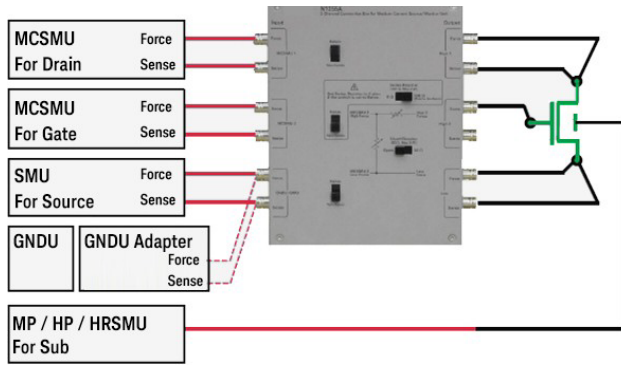

Figure 9. N1255A 2-channel connection adapter for B1514A Medium Current Source/Monitor Unit

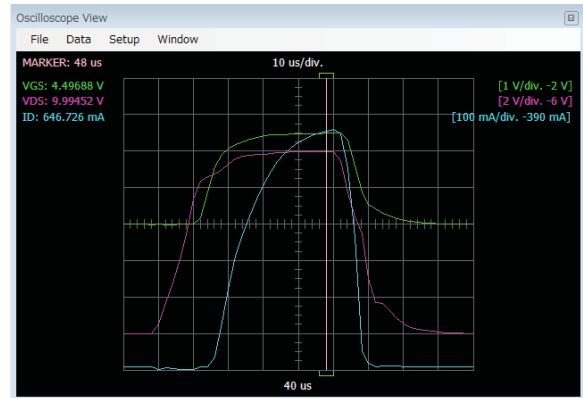

Figure 10. Oscilloscope View Measurement Example, 10 V and 50  $\mu$ s Pulse Output to Gate and Drain.

## Pulsed-IV Solution Overview—SMU (500 $\mu$ s to 2 s)

- High power pulsed IV parametric test solution
- High voltage/current characterization with 200 V voltage and 1 A current sourcing capability
- Source and measurement unit
- B1510A, B1511A, B1511B, B1517A for B1500A

The Keysight source measurement units (SMUs) for parametric/device analyzers provide wide coverage for pulsed IV parametric test, with up to 200 V and 1 A when using the high power SMU (HPSMU). This allows you to measure the IV characteristics of high power devices (such as those used in RF applications) and avoid self-heating effects. Keysight SMUs have a pulse width range of 500  $\mu$ s to 2 s.

This method is well-proven and has been used for a long time by many researchers and engineers both in and out of the semiconductor industry.

### Features

- Wide coverage: Up to 200 V and 1 A (High power SMU)
- Pulse width range of 500  $\mu$ s to 2 s
- Synchronized pulse measurement capability
- One-box solution that does not require any other external equipment or complicated cable connections.
- Proven accurate and conventional pulsed IV measurement
- Easy setup using Keysight EasyEXPERT software



Target device:

- RF signal FET devices
- High power semiconductor devices

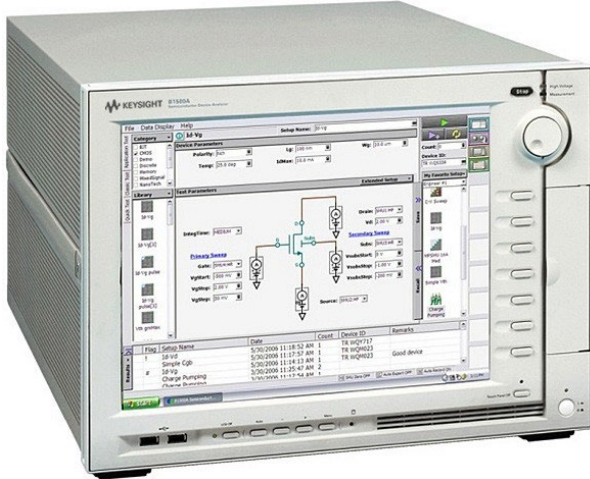

Figure 11. Keysight B1500A Semiconductor Device Analyzer

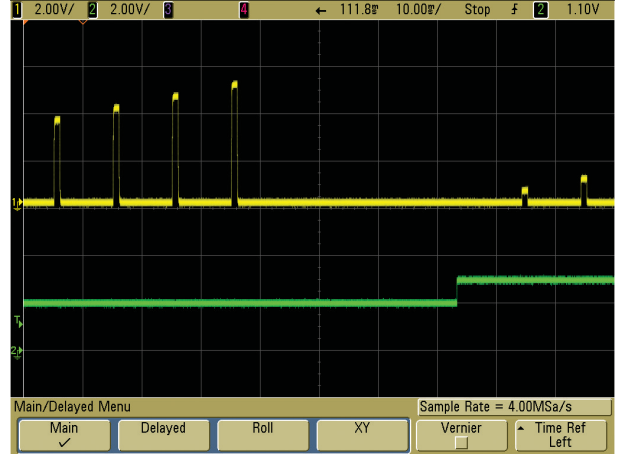

Figure 12. Example of SMU output in pulse measurement

Table 3. Key specifications of SMUs

Key specifications of Keysight SMUs for pulsed-IV measurement				
SMU	Max. voltage	Max. current	Min. current resolution	Max. pulse width
<b>B1500A</b>				
B1510A HPSMU	200 V	1 A	10 fA	2 s
B1511A/ B1511B MPSMU	100 V	100 mA	10 fA	2 s
B1517A HRSMU	100 V	100 mA	1 fA	2 s
<b>E5270B</b>				
E5280B HPSMU	200 V	1 A	10 fA	2 s
E5281B MPSMU	100 V	100 mA	10 fA	2 s
E5287A HRSMU	100 V	100 mA	1 fA	2 s

## Tips for Accurate Pulsed-IV Parametric Test Measurement

The tips listed below are based on years of Keysight's experience making high-frequency and pulsed measurement. For additional help and information please refer to the referenced application notes or contact your local Keysight instrument support.

### Take into account the frequency characteristics of the entire measurement system

A narrow pulse, especially one under 100 ns, includes high-frequency harmonics over 1 GHz. If the frequency response of the cables and probes cannot support this bandwidth then the shape and integrity of the pulses will be compromised and the measurement data will not be accurate. For this reason it is necessary to consider the measurement setup as a whole, including the signal return path and the positioning of the DUT and probe pads.

We highly recommend using RF probes with a Ground-Signal (GS) or Ground-Signal-Ground (GSG) RF layout design in the TEG<sup>1</sup>.

1. \* TEG: Test Element Group

### Preventing DUT oscillation

In general, devices with high gain factors ( $G_m$  or  $H_{fe}$ ) such as HEMTs are very susceptible to oscillations when making parametric measurements. Of course, if any oscillation occurs then the measurement data is not accurate.

Inserting ferrite beads around the probes can be effective in preventing DUT oscillation. In addition, the ferrite beads also reduce parasitic capacitive feedback which improves the high frequency characteristics of the overall system.

For more information, please refer the application note, Techniques & Applications for High Throughput & Stable Characterization (Literature number: 5950-2954), or the B1500A User's Guide (Keysight part number: B1500-90000).

## Specifications and feature comparison

### Pulsed IV parametric test

Table 4. Specifications and feature comparison — Pulsed IV parametric test

Comparison table of key specifications and features				
Solution	B1530A WGFMU	B1525A HV-SPGU	B1514A MCSMU	SMU (MP/HP/HR)
Analyzer support	B1500A	B1500A	B1500A	B1500A, 4155C, 4156C
Maximum gate/drain voltage	10 V/10 V	40 V/40 V	30V / 30 V	100 V (MPSMU/HRSMU) 200 V (HPSMU) <sup>1</sup>
Maximum drain current	10 mA	400 mA	1 A	100 mA (MPSMU/HRSMU) 1 A (HPSMU) <sup>1</sup>
Minimum drain current res.	2 nA (effective)	40 $\mu$ A	10 pA 10 fA (MPSMU/HPSMU)	1 fA (HRSMU) 10 fA (MPSMU/HPSMU)
Pulse width range	100 ns – 10 s	5 $\mu$ s – 10 s	50 $\mu$ s – 2 s	500 $\mu$ s – 2 s
DC (SMU) measurement	Yes	Yes <sup>1</sup>	Yes <sup>2</sup>	Yes
Waveform monitor function	Yes	No	Yes	No
Drain pulse	Yes	Yes	Yes	Yes
Software	EasyEXPERT/ Instrument library	EasyEXPERT/ Flex	EasyEXPERT/ Flex	EasyEXPERT/ Flex
External equipment	None	None	None	None
Connection	Connect WGFMU directly	Connect SPGU directly	N1255A Connection box	Connect SMU directly

1. Sample program doesn't support DC measurement function.
2. Maximum current of DC mode on MCSMU module is 100 mA.

## Information Resource

Table 5. Reference and resource

Literature	Pub type	Pub number
<i>Keysight B1500A Semiconductor device analyzer</i>	Brochure	5991-2443EN
<i>Keysight B1500A Semiconductor Device Analyzer</i>	Technical data sheet	5989-2785EN
<i>Keysight B1530A Waveform Generator/Fast Measurement Unit (WGFMU)</i>	Product note	5990-4567EN
<i>High Power Pulsed IV Solution Utilizing the B1525A HV-SPGU</i>	Technical overview	5990-3786EN
<i>Techniques &amp; Applications for High Throughput &amp; Stable Characterization</i>	Application note	5950-2954

Web resource	Website
Visit our Web sites for additional product information and literature.	
<i>B1500A semiconductor device analyzer</i>	<a href="http://www.keysight.com/find/b1500a">www.keysight.com/find/b1500a</a>
<i>B1530A Waveform Generator/Fast Measurement Unit</i>	<a href="http://www.keysight.com/find/wgfm">www.keysight.com/find/wgfm</a>
<i>EasyEXPERT/Desktop EasyEXPERT</i>	<a href="http://www.keysight.com/find/easyexpert">www.keysight.com/find/easyexpert</a>
<i>E5270B 8-slot Precision Measurement Mainframe</i>	<a href="http://www.keysight.com/find/e5270b">www.keysight.com/find/e5270b</a>

## B1500A Now Supported in Windows 10

B1500A PC platform has been renewed. It includes Windows 10 OS, faster CPU, 8 GB of memory and a solid state drive (SSD). The latest PC platform enables you to perform your software tasks easily while improving your total computing performance. Windows 10 upgrade option is also available.

For more detail: <https://literature.cdn.keysight.com/litweb/pdf/5991-3327EN.pdf>



Keysight B2900A Series Precision Source/Measure Unit  
[www.keysight.com/find/B2900A](http://www.keysight.com/find/B2900A)



Keysight B1500A Semiconductor Device Analyzer  
[www.keysight.com/find/B1500A](http://www.keysight.com/find/B1500A)

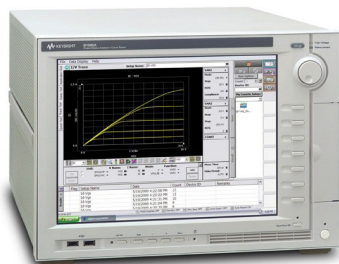

Keysight B1505A Power Device Analyzer/Curve Tracer  
[www.keysight.com/find/B1505A](http://www.keysight.com/find/B1505A)

Learn more at: [www.keysight.com](http://www.keysight.com)

For more information on Keysight Technologies' products, applications or services, please contact your local Keysight office. The complete list is available at: [www.keysight.com/find/contactus](http://www.keysight.com/find/contactus)

